

RHG002 SPECIFICATIONS

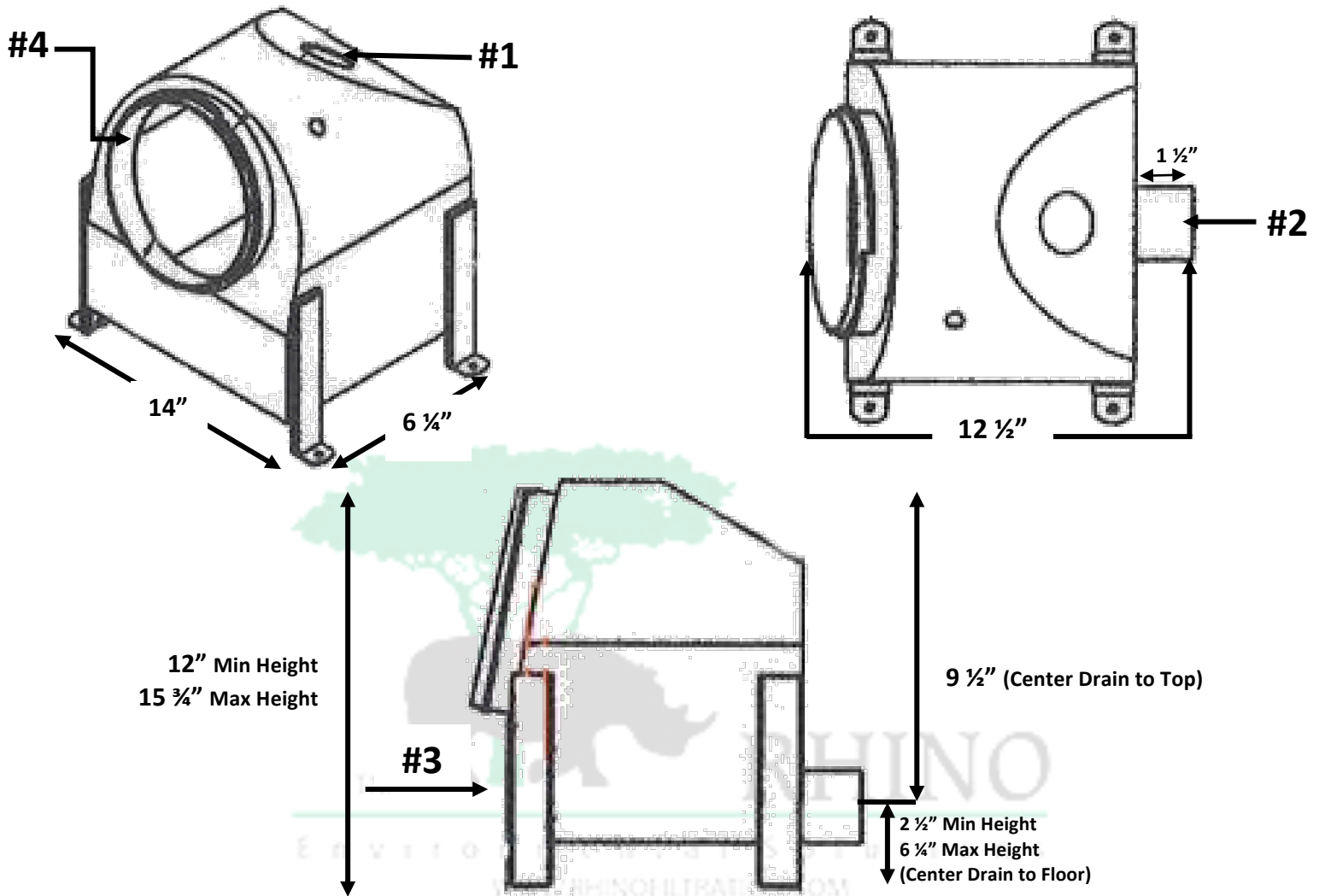

LEGEND

1. 2" Inlet Spout to hold filter bag (Incl.)
2. 2" Outlet Pipe
3. Adjustable Stainless Steel Legs (Plastic Covers Incl.)
4. 8" O.D Opening to remove filter bag (Clear Lid Incl.)

FEATURES

- Molded in one piece to prevent leaks.
- Constructed of HMW HDPE Plastic which is resistant to high water temperatures, corrosion, and solvents.
- Includes 2 removable ABS Plastic strainer type trays to hold filter and drain out water.
- Requires P-Trap before inlet spout when connecting unit to direct drain.